

AFT 40K Deckpal Blaster

- ✓ Core Inside - Advanced Spray Bar with 16 jets and different angles create stronger jets and higher blasting efficiency.
- ✓ Core Inside - AFT patented Magnetic Break UHP Rotary Swivel keep the Spray Bar working at the perfect rotational speed. Breakthrough patented cartridge design with the least parts. Simplest maintenance
- ✓ Lasting longlife of the HP Sealing kit.
- ✓ A vacuum valve and dual evacuation outlet on the cleaning plate to ensure high efficiency of the entire vacuum recycling.
- ✓ Multi-layer nylon brush effectively prevent the leakage of sewage and impurities.

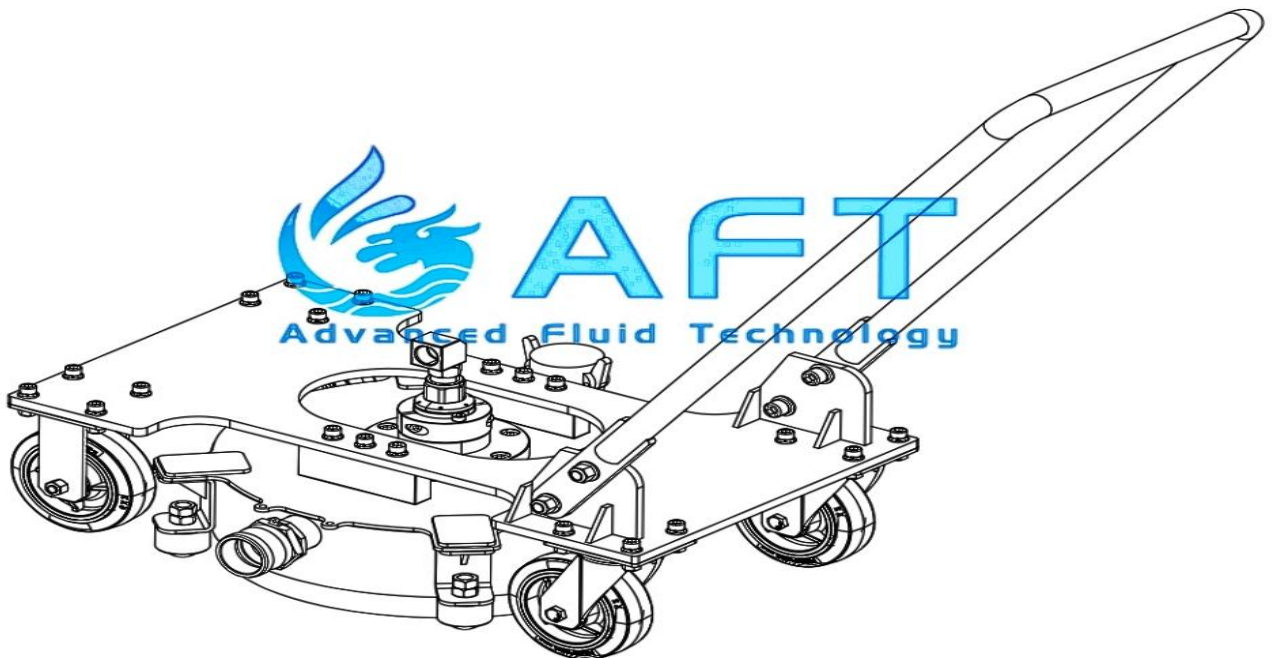

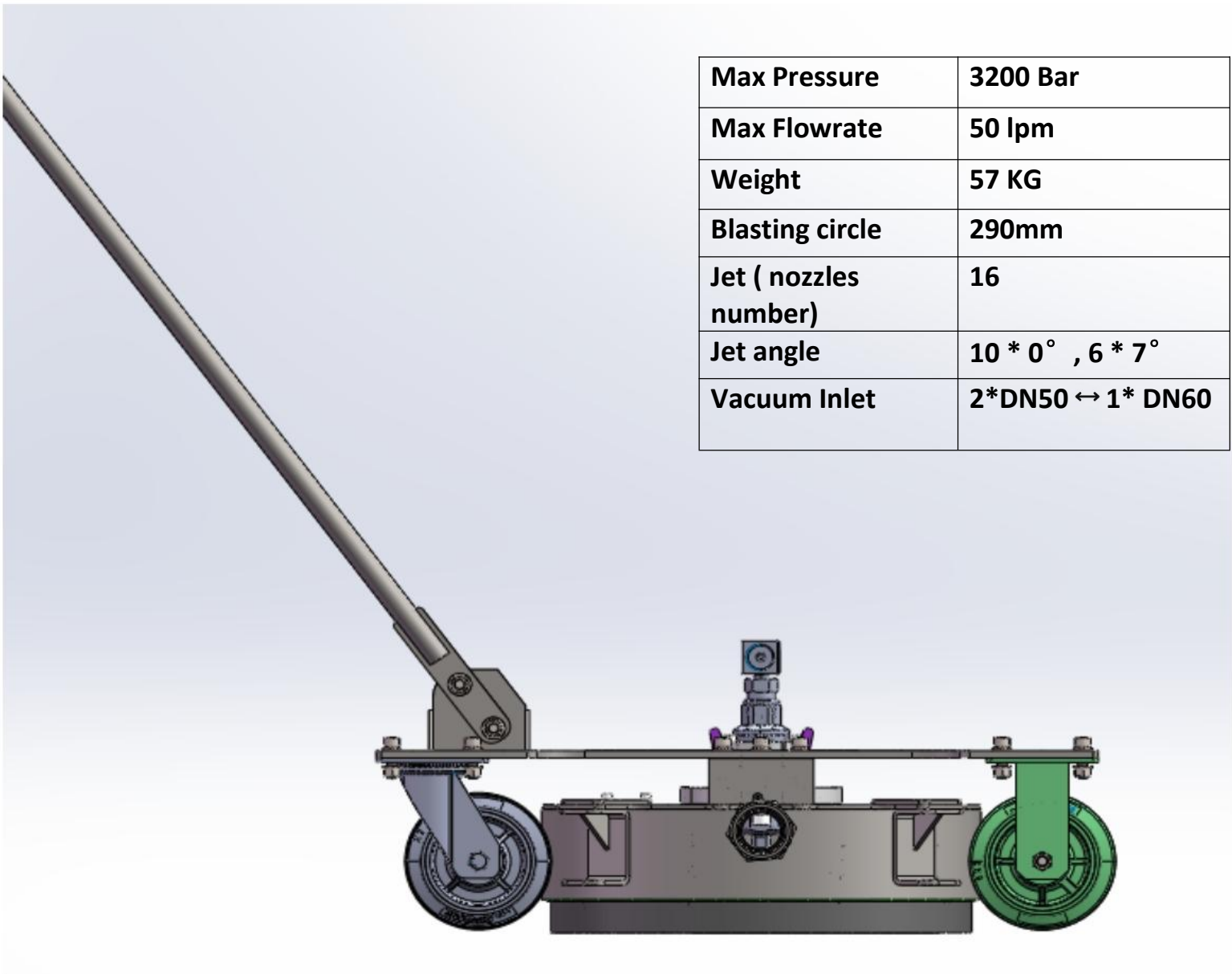
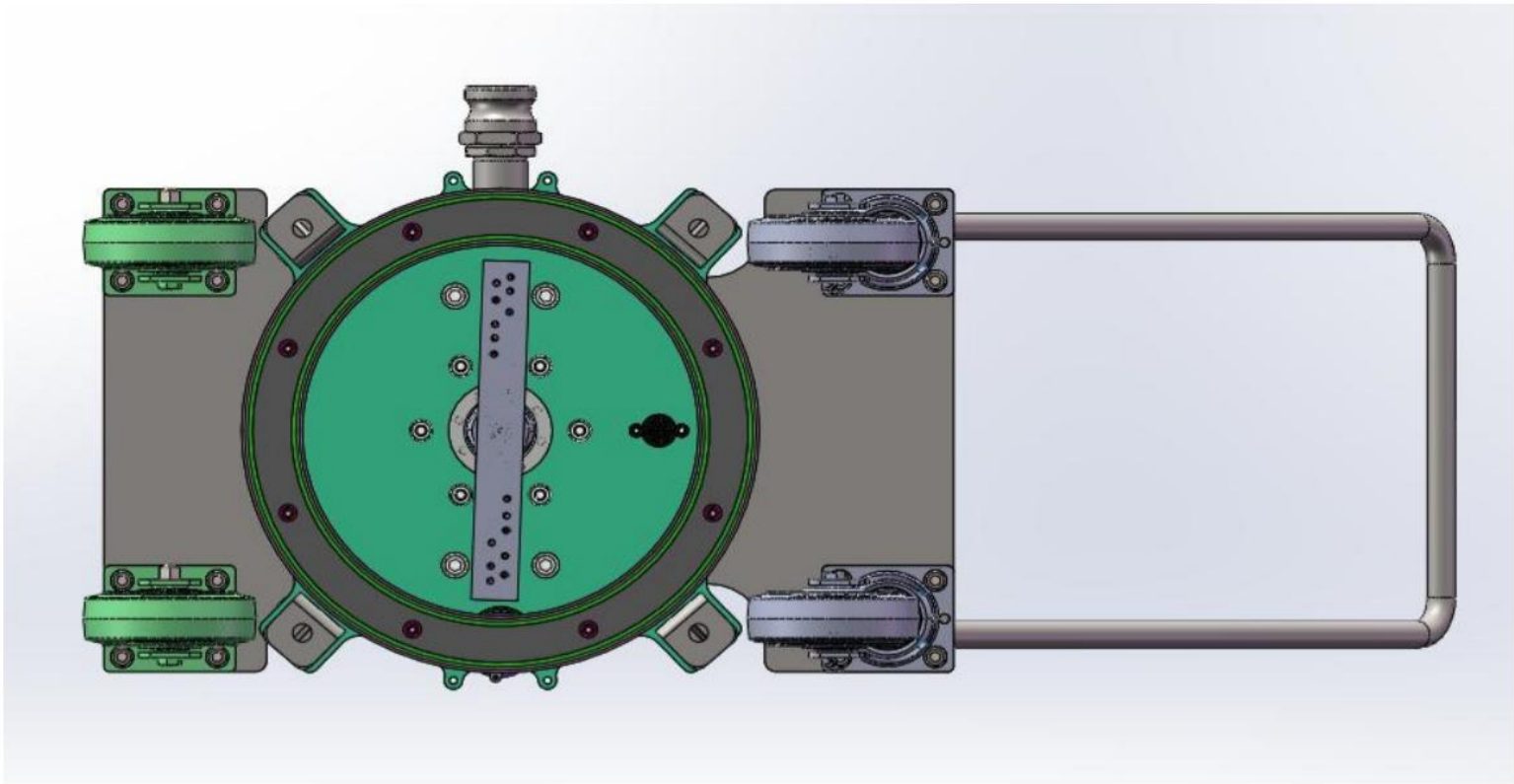

| | |
|------------------------------|-------------------------|
| Max Pressure | 3200 Bar |
| Max Flowrate | 50 lpm |
| Weight | 57 KG |
| Blasting circle | 290mm |
| Jet (nozzles number) | 16 |
| Jet angle | 10 * 0° , 6 * 7° |
| Vacuum Inlet | 2*DN50 ↔ 1* DN60 |



2800 Bar Rotary Swivel (Magnetic Break)

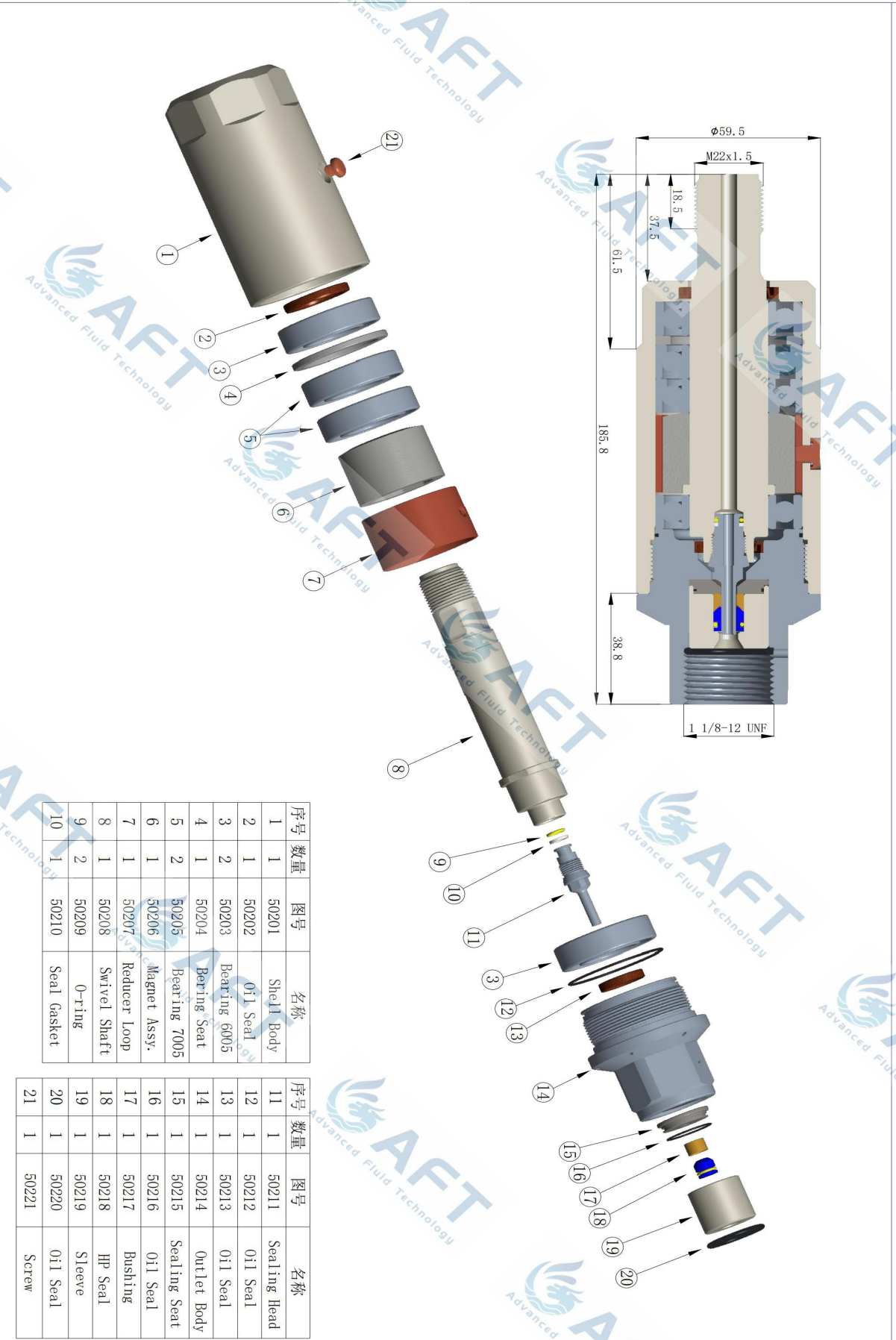

| 序号 | 数量 | 图号 | 名称 |
|----|----|-------|--------------|
| 1 | 1 | 50201 | Shell Body |
| 2 | 1 | 50202 | Oil Seal |
| 3 | 2 | 50203 | Bearing 6005 |
| 4 | 1 | 50204 | Bearing Seat |
| 5 | 2 | 50205 | Bearing 7005 |
| 6 | 1 | 50206 | Magnet Assy. |
| 7 | 1 | 50207 | Reducer Loop |
| 8 | 1 | 50208 | Swivel Shaft |
| 9 | 2 | 50209 | O-ring |
| 10 | 1 | 50210 | Seal Gasket |

| 序号 | 数量 | 图号 | 名称 |
|----|----|-------|--------------|
| 11 | 1 | 50211 | Sealing Head |
| 12 | 1 | 50212 | Oil Seal |
| 13 | 1 | 50213 | Oil Seal |
| 14 | 1 | 50214 | Outlet Body |
| 15 | 1 | 50215 | Sealing Seat |
| 16 | 1 | 50216 | Oil Seal |
| 17 | 1 | 50217 | Bushing |
| 18 | 1 | 50218 | HP Seal |
| 19 | 1 | 50219 | Sleeve |
| 20 | 1 | 50220 | Oil Seal |
| 21 | 1 | 50221 | Screw |

Maintenance Instruction

1. Unload the O-Ring with a Hex Wrench

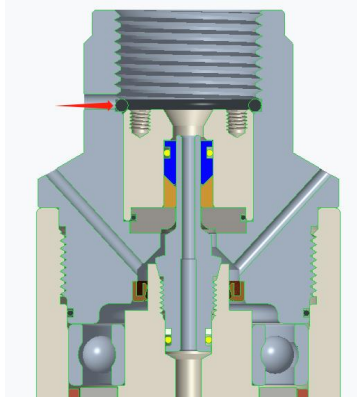

2. Pull out the cartridge kit with M4 screws

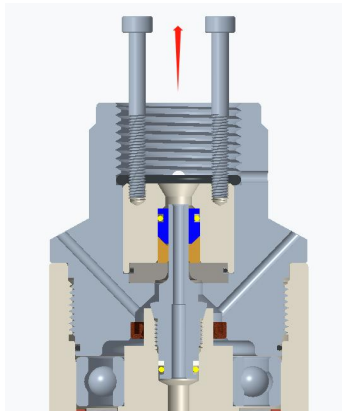

3. Unload the Sealing Seat

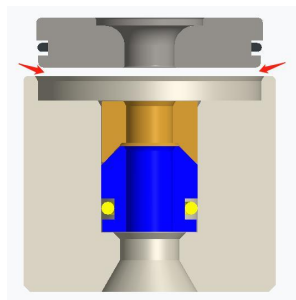

4. Unload the Sealing Seat

